

FANMEF - Series Eco-Watt Mixed-flow Inline Duct Fan

Features

- High efficiency and energy saving: use a DC variable frequency motor (permanent magnet synchronous motor) for lower energy consumption.
Meet EU ERP2018 energy efficiency standards.
- Free speed control: 0-10V voltage speed control and PWM signal speed control.
- Stable performance: set with slow starting, no influence during voltage fluctuation.
- Long durability: low vibration, low noise and continuous operation.
- Protection class: IP44
- Operating temperature range: -20°C ~60°C

Performance Parameter

Model	Voltage	Current (Amps)	Power (W)	Speed (RPM)	Airflow		Air Pressure (Pa)	Net Weight (kgs)
					(m ³ /h)	(m ³ /s)		
FANMEF-150	100~140	0.47 MAX 0.94	70	3000	647	179.7	503	2.6
FANMEF-200	100~120 200~220	2.1 1.05	165	3000	1250	347.2	746	4.9

Dimensions

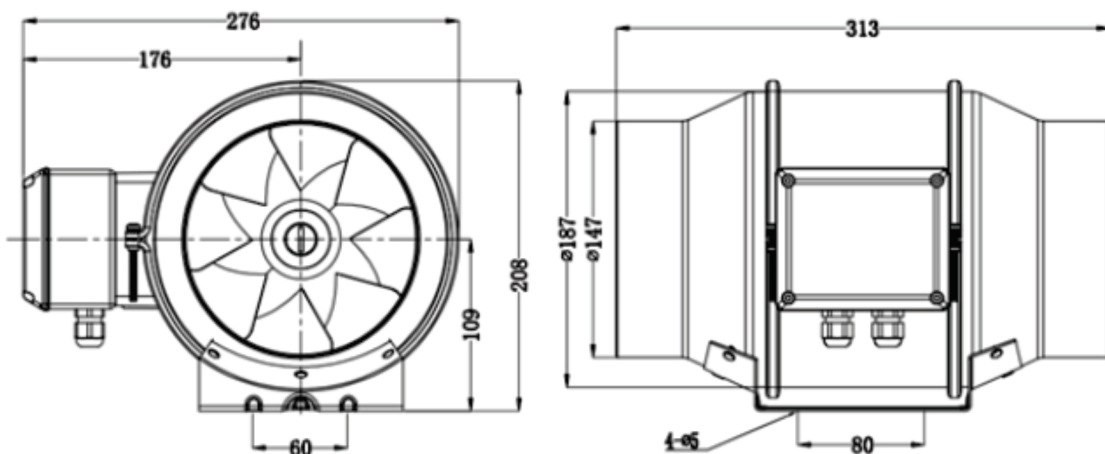

FANMEF - Series Eco-Watt Mixed-flow Inline Duct Fan

Performance Curves

