

FANMAN150

6" 150mm Circular Centrifugal Fan

Features

- 6inch 150mm
- IP44 protection level
- Iron environmental protection material, fashion design.
- Using Japan NMB bearing, working life more than 50,000 hours
- External rotor motor with low-temperature rise.
- With CE, and UL certification.

- Casing is made of iron.
- Backward-curved centrifugal impeller using PA66(FR).
- ABS(FR) connection box.
- External rotor motor with low temperature rise.
- Motor is equipped with automatic reset thermal overload protection.
- NSK ball bearing, acceptable for continuous operation of 50000h.
- Operating temperature range: -20°C~60°C.
- Insulation Class: F.
- Protection class: IP44.

Performance Parameter

Model	Voltage/ Frequency (V/Hz)	Current (Amps)	Power (W)	Rotated Speed (RPM)	Airflow (M ³ /H)	Air Pressure (Pa)	Net Weight (kg)
FANMAN150	220~240/50	0.58	110	2450	680	446	4.30
	100~120/60	1.30	140	2550	707	483	

Dimensions

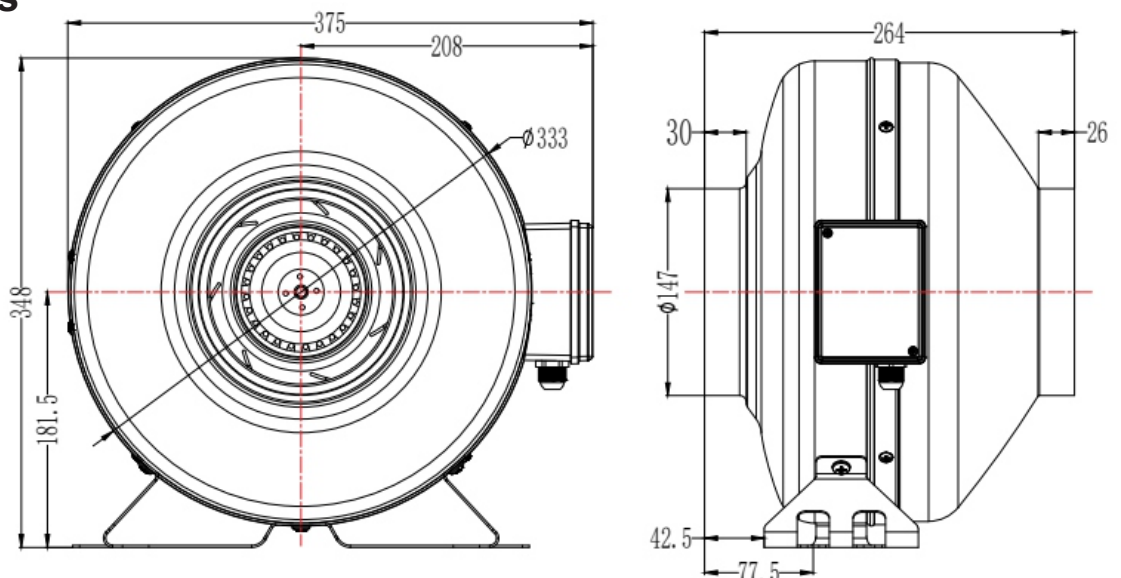

FANMAN150

6" 150mm Circular Centrifugal Fan

Performance Curves

